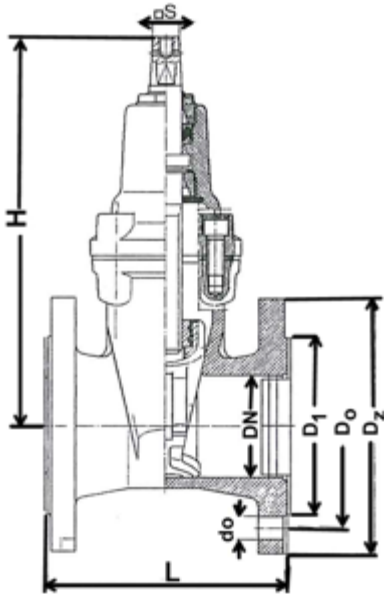

**Fig. 027 / 58 PN16
ACS**



Vanne à passage direct

- Corps ovale
- Fonte EN-GJS500-7
- Fermeture sens horaire
- Opercule surmoulé EPDM
- Pour les eaux potables et autres fluides non-agressifs

Gate valve

- Oval Body
- Ductile iron EN-GJS500-7
- Closing close wise
- Wedge coated with EPDM
- For drinking water and other non aggressive medium

Keilvalschieber

- Spherguss EN-GJS500-7
- Schliessung nach rechts
- Keil mit EPDM beschichtet
- Für Trinkwasser und anderen nicht aggressive Flüssigkeiten

Dimensions entre brides selon EN 558-1 serie 15

Length according to EN 558-1 series 15

Baulänge nach EN 558-1 Grundreihe 15

DN	L	H	D _z	D _o		D ₁	s	d _o		n		Dk Øvolant	Poids
				PN16	PN10			PN16	PN10	PN16	PN10		Weight
mm													kg
40	240	233	150	110	110	88	14	18	18	4	4	160	9,4
50	250	240	165	125	125	102	14	18	18	4	4	160	10,2
65	270	277	185	145	135	122	17	18	18	4	4	160	16,8
80	280	300	200	160	160	138	17	18	18	8	4	160	19,5
100	300	339	220	180	180	158	19	18	18	8	8	200	25,6
125	325	376	250	210	210	188	19	18	18	8	8	250	33,4
150	350	438	285	240	240	212	19	22	22	8	8	250	46,8
200	400	512	340	295	295	263	24	22	22	12	8	250	78,1
250	450	637	405	355	350	320	27	26	22	12	12	250	100,0
300	500	712	460	410	400	378	27	26	22	12	12	250	137,3

Conditions de service

Working conditions

Betriebsdruck und Temperatur

Température (°C)	80
Pression / Pressure / Druck (bar)	16

Matières / Materials / Material

- Corps :** EN-GJS500-7
- Chapeau :** EN-GJS500-7
- Opercule :** EN-GJS500-7 - EPDM
- Tige :** X20 Cr13
- Volant :** EN-GJS500-7
- Joint de chapeau :** EPDM
- Joint torique :** EPDM

- Body :** EN-GJS500-7
- Bonnet :** EN-GJS500-7
- Wedge :** EN-GJS500-7 - EPDM
- Stem :** X20 Cr13
- Handwheel :** EN-GJS500-7
- Bonnet gasket :** EPDM
- O-ring :** EPDM

- Gehäuse :** EN-GJS500-7
- Deckel :** EN-GJS500-7
- Keil :** EN-GJS500-7 - EPDM
- Spindel :** X20 Cr13
- Handrad :** EN-GJS500-7
- Dichtung Gehäuse/Deckel :** EPDM
- O-Ring :** EPDM

04-2013



ROBINETTERIE INDUSTRIELLE
30 rue Henri Durre - 59590 RAISMES
Tél. 33 (0)3 27 36 70 12 - Fax 33 (0)3 27 36 75 20

CE PED 97/23



www.stemat-jansen.fr

Document non contractuel