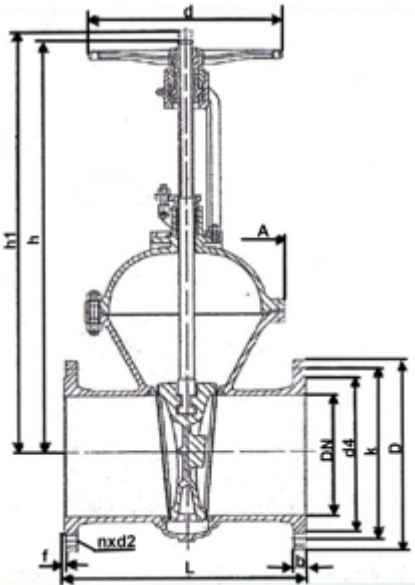

Fig. 033 / 78 PN40 ACS



Vanne à passage direct

- Corps acier , revêtu Epoxy
- Tige montante
- Coin flexible PN40
- Pour les eaux potables

Gate valve

- Cast steel
- With Epoxy Coating
- Outside stem
- Flexible wedge PN40
- For drinking water

Keilrundschieber

- Stahlguss
- mit Epoxy Beschichtung
- Aussen Spindel
- Niro dichtend
- Für Trinkwasser

Dimensions entre brides selon DIN EN 558 – 1, série 26

Face to face dimensions according to DIN EN 558 – 1, series 26

Baulänge nach DIN EN 558 – 1, Grundreihe 26

DN	L	D	K	d4	d	v	hl	A	n	d2	b	f	Poids
													Weight
													Gewicht
													kg
40	240	150	110	88	200	330	385	170	4	18	18	3	22
50	250	165	125	102	200	340	395	180	4	18	20	3	23
65	290	185	145	122	225	410	490	205	8	18	22	3	33
80	310	200	160	138	225	415	515	215	8	18	24	3	36
100	350	235	190	162	250	485	610	255	8	22	24	3	54
125	400	270	220	188	360	590	730	290	8	26	26	3	78
150	450	300	250	218	400	670	840	325	8	26	28	3	103
200	550	375	320	285	400	815	1030	400	12	30	34	3	173
250	650	450	385	345	500	965	1235	460	12	33	38	3	285
300	750	515	450	410	500	1155	1380	550	16	33	42	4	444
350	850	580	510	465	560	1244	1607	630	16	36	46	4	700
400	950	660	585	535	630	1417	1837	710	16	39	50	4	910
500	1150	755	670	615	1150	1719	2239	790	20	42	52	4	1448

Conditions de service

Working conditions

Betriebsdruck und Temperatur

Température (°C)	0	80
Pression / Pressure / Druck (bar)	40	40

Matières / Materials / Material

Corps : GSC25N/GP240GH/1.0619N
Chapeau : GSC25N/GP240GH/1.0619N
Opercule : GSC25N/GP240GH/1.0619N
Volant : EN GJS-400
Tige : X 20 CR 13
Etanchéité de tige : Graphite
Sièges : X 20 CR 13
Etanchéité corps/chapeau : Metal-graphite

Body : GSC25N/GP240GH/1.0619N
Bonnet : GSC25N/GP240GH/1.0619N
Wedge : GSC25N/GP240GH/1.0619N
Handwheel : EN GJS-400
Stem : X 20 CR 13
Gland packing : Graphite
Seats : X 20 CR 13
Gasket body/bonnet : Metal-graphite

Gehäuse : GSC25N/GP240GH/1.0619N
Deckel : GSC25N/GP240GH/1.0619N
Keil : GSC25N/GP240GH/1.0619N
Handrad : EN GJS-400
Spindel : X20 CR13
Packung : Graphit
Sitzring : X20 CR13
Dichtung : Metal-graphit

04-2013